

**TOP VIEW**

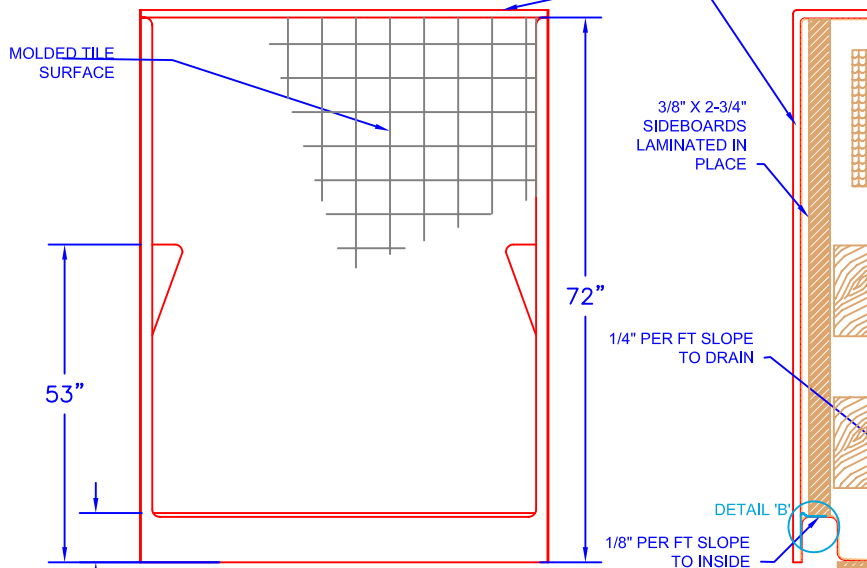

**FRONT VIEW**

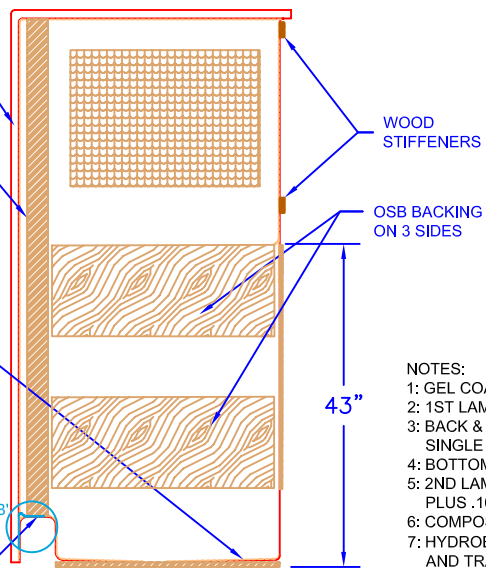

**SIDE VIEW**

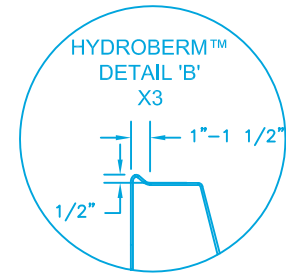

- NOTES:
- 1: GEL COAT THICKNESS .020" ±.005.
  - 2: 1ST LAMINATE .125" NOMINAL THICKNESS.
  - 3: BACK & SIDE WALLS REINFORCED WITH WOOD & SINGLE FACED CORRUGATE.
  - 4: BOTTOM BOARD REINFORCED WITH 5/8" PARTICLE BOARD.
  - 5: 2ND LAMINATE COMPLETELY COVERS ALL REINFORCEMENTS PLUS .100" ADDED TO UNREINFORCED AREAS.
  - 6: COMPOSITE CONSISTS OF: A) GELCOAT, B) RESIN, C) GLASS, D) FILLER
  - 7: HYDROBERM™ MOISTURE BARRIER IS A PROPRIETARY DESIGN AND TRADEMARK OF FIBER CARE BATHS, INC.. PATENT PENDING.

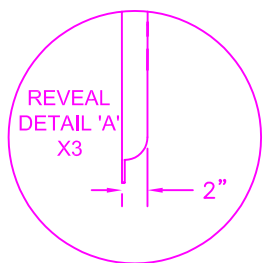

UNIT PART NUMBERS		UNLESS OTHERWISE SPECIFIED TOLERANCES ARE AS FOLLOWS	
RIGHT HAND UNIT	<b>ES60-34NS</b>	DECIMAL:	FRACTIONAL: ±1/8"
		.XX = ±.010 .XXX = ±.005	ANGULAR: ±1/2°
LEFT HAND UNIT	<b>ES60-34NS</b>	CAPACITY/ OPERATING LEVEL:	GAL
		CAPACITY/ OVERFLOW LEVEL:	GAL
		APPROX. UNIT WEIGHT:	LBS
		APPROX. SHIPPING WEIGHT:	LBS

THE INFORMATION CONTAINED IN THIS DRAWING IS THE SOLE PROPERTY OF FIBER CARE BATHS, INC. ANY REPRODUCTION OR UNAUTHORIZED USE IN PART OR AS A WHOLE WITHOUT THE WRITTEN PERMISSION OF FIBER CARE BATHS, INC. IS STRICTLY PROHIBITED. PRODUCT CONFIGURATION, DIMENSIONS, STANDARD ACCESSORIES, MATERIALS COMPOSITION AND CONSTRUCTION ARE SUBJECT TO CHANGE WITHOUT NOTICE.

# Fiber Care Baths, Inc.

9832 Yucca Rd.  
Adelanto, CA 92301  
Phone: 760-246-0019  
Fax: 760-246-5189

TITLE				REV
<b>SHOWER STALL, 3 WALL, NO SEATS ETERNA TILE</b>				
DWN	SIZE	MODEL #	<b>ES60-34NS</b>	A
KBP	A			
DATE	SCALE	PAGE	1 OF 1	
7/7/03	NTS			