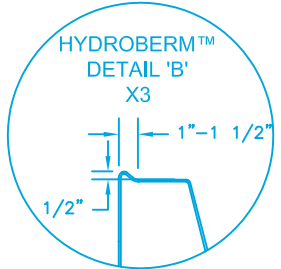
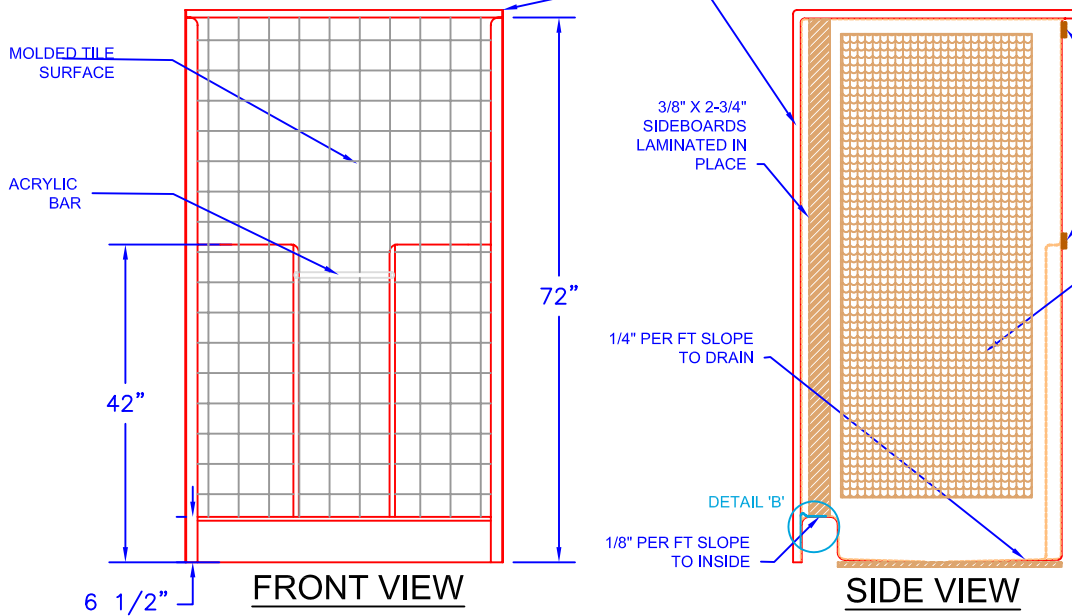
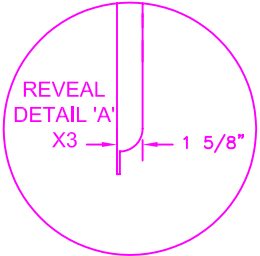

PHOTO VIEW



- NOTES:
- 1: GEL COAT THICKNESS .020" ±.005.
 - 2: 1ST LAMINATE .125" NOMINAL THICKNESS.
 - 3: BACK & SIDE WALLS REINFORCED WITH WOOD & SINGLE FACED CORRUGATE.
 - 4: BOTTOM BOARD REINFORCED WITH 5/8" PARTICLE BOARD.
 - 5: 2ND LAMINATE COMPLETELY COVERS ALL REINFORCEMENTS PLUS .100" ADDED TO UNREINFORCED AREAS.
 - 6: COMPOSITE CONSISTS OF: A) GELCOAT, B) RESIN, C) GLASS, D) FILLER
 - 7: HYDROBERM™ MOISTURE BARRIER IS A PROPRIETARY DESIGN AND TRADEMARK OF FIBER CARE BATHS, INC.. PATENT PENDING.



UNIT PART NUMBERS		UNLESS OTHERWISE SPECIFIED TOLERANCES ARE AS FOLLOWS	
RIGHT HAND UNIT	ES44-34	DECIMAL: .XX = ±.010 .XXX = ±.005	FRACTIONAL: ±1/8" ANGULAR: ±1/2°
LEFT HAND UNIT		CAPACITY/ OPERATING LEVEL: GAL	
THE INFORMATION CONTAINED IN THIS DRAWING IS THE SOLE PROPERTY OF FIBER CARE BATHS, INC. ANY REPRODUCTION OR UNAUTHORIZED USE IN PART OR AS A WHOLE WITHOUT THE WRITTEN PERMISSION OF FIBER CARE BATHS, INC. IS STRICTLY PROHIBITED. PRODUCT CONFIGURATION, DIMENSIONS, STANDARD ACCESSORIES, MATERIALS COMPOSITION AND CONSTRUCTION ARE SUBJECT TO CHANGE WITHOUT NOTICE.		CAPACITY/ OVERFLOW LEVEL: GAL	
		APPROX. UNIT WEIGHT:	LBS
		APPROX. SHIPPING WEIGHT:	LBS

Fiber Care Baths, Inc.

9832 Yucca Rd.
Adelanto, CA 92301
Phone: 760-246-0019
Fax: 760-246-5189

TITLE				REV
SHOWER STALL, 3 WALL ETERNA TILE				
DWN	SIZE	MODEL #	PAGE	1 OF 1
KBP	A	ES44-34		
DATE	SCALE	NTS		
5/6/03				